

# EU-DECLARATION of CONFORMITY



The manufacturer: Company  
Hagleitner Hygiene International GmbH  
Lunastraße 5  
5700 Zell am See, Austria

declares under his sole responsibility for the following system:

<b>XIBU TISSUEPAPER hybrid</b>	
<b>Type: Dispenser</b>	<b>Mach. Nr.: P0312, P0445</b>

that all the relevant provisions of following *European Directives* are fulfilled:

2014/53/EU Radio Equipment Directive  
2014/30/EU Electromagnetic Compatibility  
2022/30/EU Commission Delegated Regulation (EU) 2022/30

and that the system corresponds with the relevant sections of following standards and/or other normative documents:

EN ISO 12100:2010 Safety of machinery. General principles for design. Risk assessment and risk reduction  
EN 303 446-1 V1.2.1:2019 Electro Magnetic Compatibility (EMC) standard for combined and/or integrated radio and non-radio equipment



Zell am See, 15.01.2026

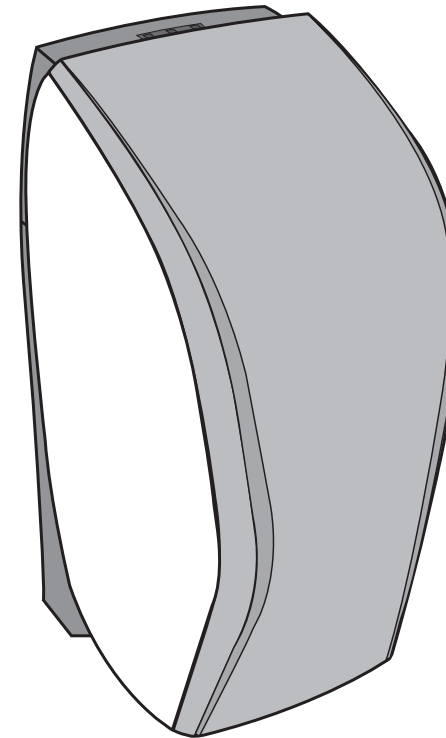

Hans Georg Hagleitner  
Chief Executive Officer  
Hagleitner Hygiene International GmbH

## CORE toilet paper dispenser



	<p>Please scan this QR code for instructions:</p>	 ISO-7010-M002
---	---	---



Art.-Nr. 20399522000  
Jan. 2026 / DSSP209-01

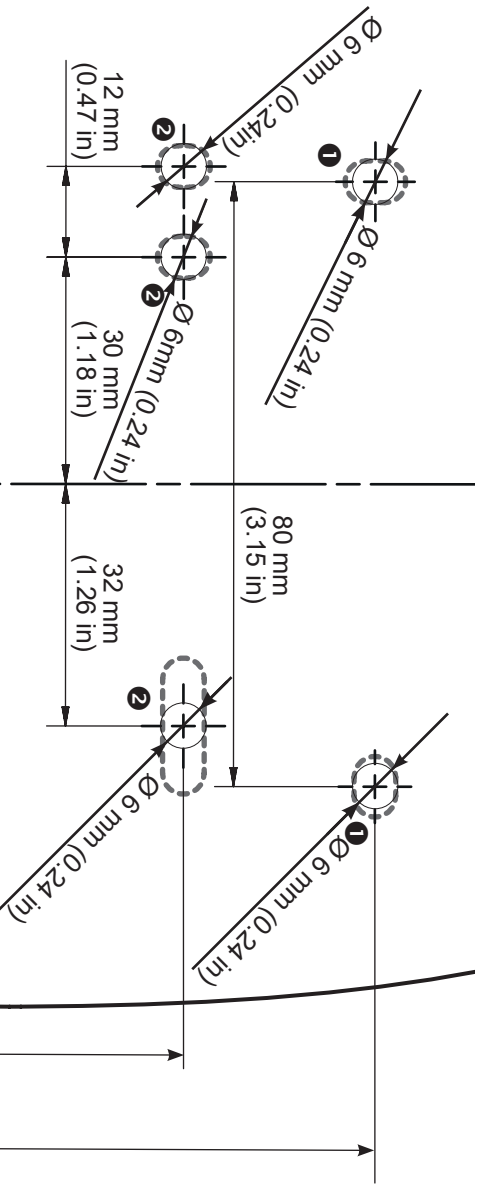

# MOUNTING TEMPLATE CORE toilet paper dispenser

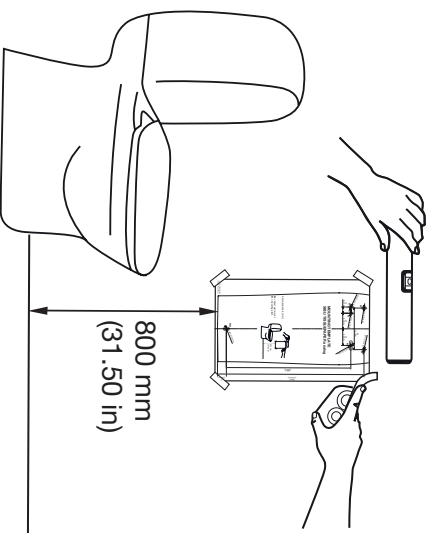

All dimensions in [mm].

- ❶ = direct wall mount
- ❷ = mounting plate

